



# Quick Start Setup Instructions for AgLeader Integra and InSight Rate Controller

**PLEASE NOTE:** Your setup may vary. Not all screens are shown. See AgLeader’s Operator’s Manual for safety information and additional setup/operating information.

## MENU STRUCTURE FOR LIQUID RATE CONTROLLER



- Home**
- Support
  - System Information
  - Event Setup



- Map**
- Field Display
  - Target Rates
  - Flow Display



- Config Selection**
- User Config.
  - Equip. Config.
  - System Config.

### System Information

AgLeader technology is a very flexible control platform with many capabilities. This quick start setup guide will show you the necessary steps to setup your AgLeader display to control AgXcel’s Fertilizer Pump Systems. Follow the general directions in your AgLeader Integra User Manual (especially under Configuration and Liquid Rate Control) or InSight User Manual (especially under Setup and Application). This manual will show you the specific numbers and settings to use with your AgXcel Fertilizer Pump System.

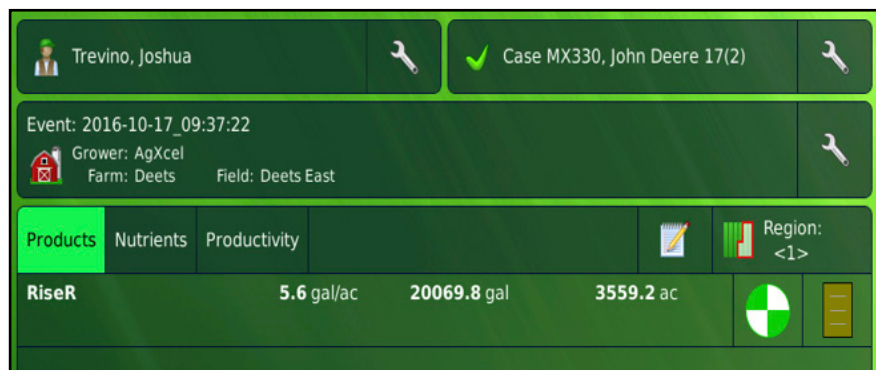

### Integra & InSight Users

Information in this manual is applicable to the InSight except for screen-shots shown in the **Setup & Operation**. The **Calibration** and **Setup** values in this section **DO** apply to the InSight. However, the InSight has a completely different screen layout and menu structure that is not shown in this manual. Use your AgLeader manual to navigate, then enter the appropriate numbers from the AgXcel manual.

### Configuration – Setup

In the **Setup** menus, you will set the AgLeader display to work properly with the AgXcel Fertilizer Pump System. Carefully follow these steps to first make the proper settings. Then, run the tests shown to verify your fertilizer system is ready to go to the field.

- From the “Home” screen, press the “Wrench” icon on the top right, which will take you to the **Configuration Setup** screen.
- Once on the **Configuration Setup** screen, choose “Equipment” on the top right of the screen.

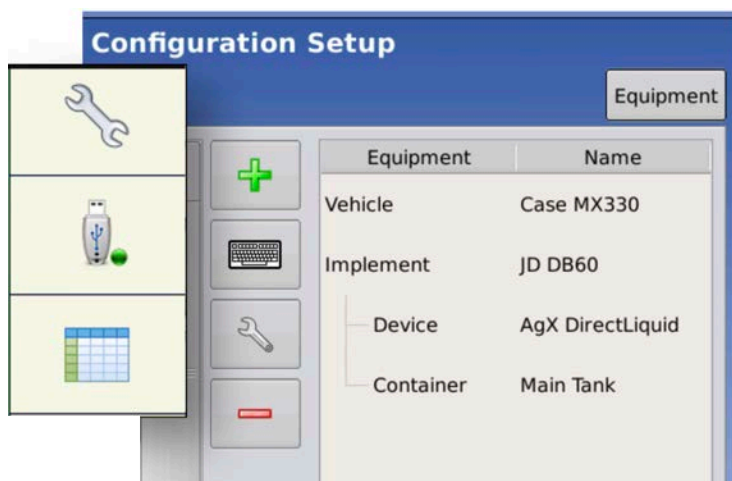



# Quick Start Setup Instructions for AgLeader Integera and InSight Rate Controller

## Configuration – Setup cont.

- Next, choose the **Implement** tab in the middle and touch the green “+” button to add a new implement.
- On the **Choose Implement Type** screen, you will need to select **Application** when setting up any AgXcel Fertilizer Pump Systems.
- Next, select the **tractor** being used with the **implement** and press the right arrow button.
- After the **tractor** has been selected, you can select an existing **implement** such as a planter or press the green “+” button to add a **new implement**.
- When adding a **new implement**, the **Implement Wizard** screen will appear where the user can define the **Make and Model** of the implement. When the information is displayed correctly, press the right arrow button.
- Next, add how the implement **attaches** to the tractor and press the right arrow button.
- On the **Application Channels** screen, press the “+ **Liquid Application**” button on the top right of the screen.
- Select the appropriate **liquid rate controller** and press the right arrow button.
- Choose a **name** and **capacity** of the **tank** being used on this implement. Press the right arrow button to continue.
- On the **Section Count Screen**, enter the number of sectional valves if applicable and press the right arrow button.

The screenshot shows the 'Setup' screen with tabs for 'Vehicle', 'Implement', and 'Controller'. The 'Implement' tab is active, showing a list of implements including 'Agxcel 15'. A green '+' button is visible. Overlaid on this is the 'Choose Implement Type' screen, which has five options: 'Tillage' (Create a tillage implement), 'Planting' (Create a planting implement), 'Application' (Create an application or strip-till implement), 'Header' (Create a harvest combine header), and 'Tile Plow' (Create a tile plow implement). The 'Application' option is highlighted.

The screenshot shows the 'Implement Wizard: Attachment Type' screen. It has a dropdown menu for 'Implement Attachment Type' with 'Rear Drawbar' selected.

The screenshot shows the 'Implement Wizard: Application Channels' screen. It has a table with columns 'Type', 'Controller', 'Channel', and 'Container'. On the right side, there are three buttons: 'Liquid Application' (with a green plus icon), 'Direct Injection', and 'Granular Application' (with a green plus icon). The 'Liquid Application' button is highlighted.

The screenshot shows the 'Equipment Setup Wizard: Rate Controller' screen. It has a dropdown menu for 'Select Application Rate Controller' with 'AgX DirectLiquid' selected. A green '+' button is visible on the right.

The screenshot shows the 'Equipment Setup Wizard: Section Count' screen. It has a text input field for 'Enter Number of Boom Sections' with the number '4' entered. Below the input field are up and down arrow buttons. A tip at the bottom reads: 'TIP: DO NOT enter the number of individual rows. For most implements, enter the number of swath sections that can be independently turned on and off.'



# Quick Start Setup Instructions for AgLeader Integera and InSight Rate Controller

## Configuration – Setup cont.

- Select the appropriate **implement swath width** and press the right arrow button.
- Verify the width of each section on the **Section Configuration Screen** and press the right arrow button to confirm it.
- Enter the **distance from the hitch to the application point or row unit** and press the green check mark to complete the setup.



- It will return you back to the **Application Channels Screen** where you can add additional applications to the implement. *For example*, if an in-furrow application set-up has been completed and a 2x2 application needed to be added the “+ **Liquid Application**” button would be pressed and the set-up process would be repeated for the 2x2 system.
- When all applications have been set up correctly, press the right arrow button
- Set up **OptRx sensors** if applicable and press the right arrow button.
- A pull behind tank can be configured on the **Hitch Point Configuration Screen**. Once configured, press the right arrow button.
- Finally, enter the **implement’s name** and press the green check mark to complete the set-up.
- When completed the implement should appear on the **Setup Screen** under the “**Implement**” tab.

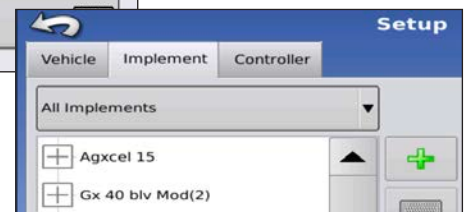
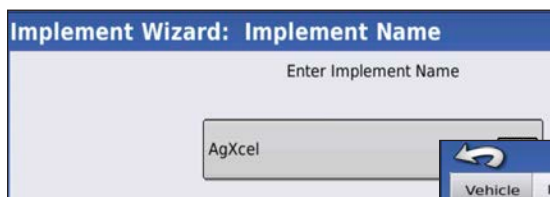
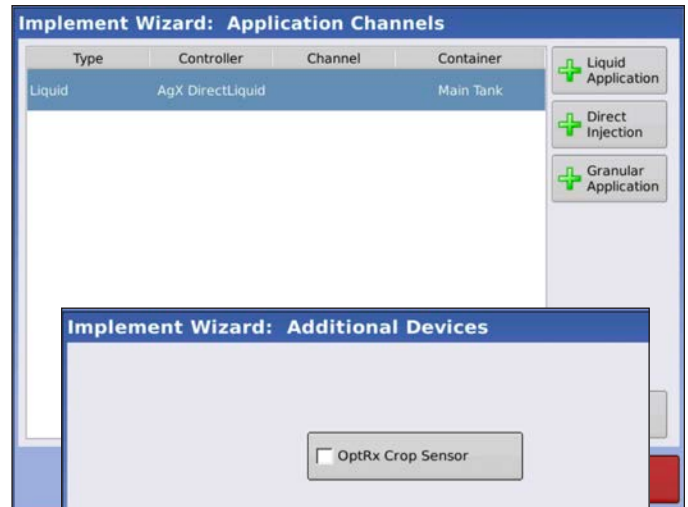



# Quick Start Setup Instructions for AgLeader Integra and InSight Rate Controller

## Configuration – Setup & Calibrate

- From the **Home Screen**, choose Setup (**Wrench icon**)
- The Setup Screen will appear. Choose the **“Configuration”** tab.
- From the **Controller Menu**, select the controller you want to change or use the Add button to create a new controller.
- Select the **Wrench icon** in the middle of the **Configuration Screen**.
- From this menu, choose the **Controller Settings** button. This will enter the controller menu where the parameters must be set to accurately control your AgXcel Fertilizer Pump System.



- The AgLeader can store multiple configurations. The controller settings used for each configuration are listed on the right of the **Configuration Setup** screen. Use **Configuration** settings to change these items. You will want to set items in the **vehicle, implement, and product** screens. Consult your manual or AgLeader dealer for assistance with those settings.
- On the **Controller Settings Screen**, set the settings as shown:

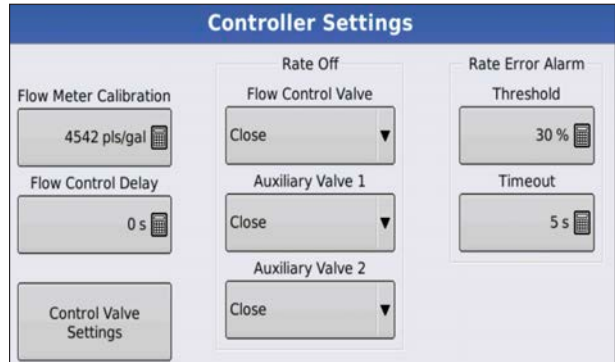
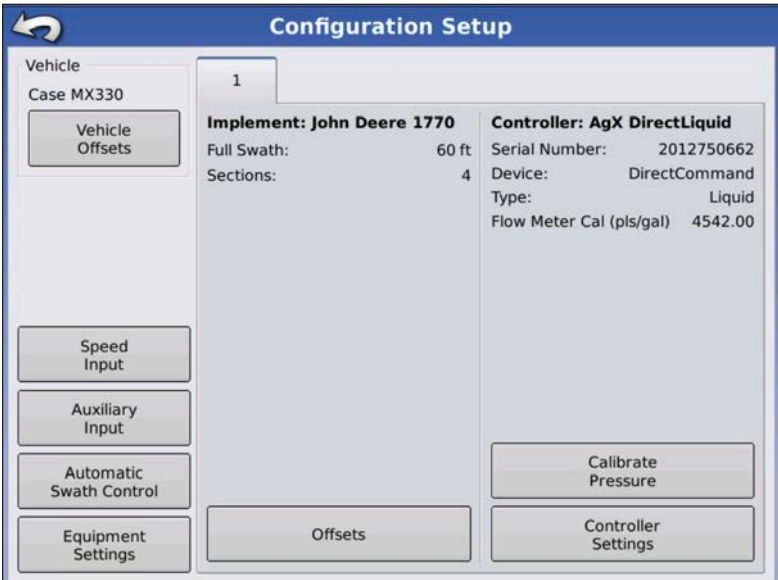

- Flow Control Delay:** All Systems.....0
- Flow Control Valve:** All Systems.....Close
- Threshold:** All Systems..... 30%
- Auxiliary Valve 1:** All Systems.....Close
- Auxiliary Valve 2:** All Systems..... Close
- Timeout:** All System ..... 5 secs

**\*Note:** The Flow Meter .08 – 1.6 is exclusively used for the GX40 Synergist to attain such low volumes. The flow meter calibration is 22710.

**Flow Meter Calibration\*:**  
See AgXcel's Flow Meter Guide



# Quick Start Setup Instructions for AgLeader Integera and InSight Rate Controller

## Configuration – Setup & Calibrate cont.

### Orion 2 Magnetic Flowmeters

- 0.08 - 1.6 GPM
- 0.13 - 2.6 GPM
- 0.3 - 5 GPM
- 0.6 - 13 GPM
- 1.3 - 26 GPM
- 2.6 - 53 GPM

### Orion 3 Magnetic Flowmeters

- |                       |       |
|-----------------------|-------|
| 0.04 - 1.6 GPM (DN3)  | 75712 |
| 0.08 - 3.17 GPM (DN4) | 37854 |
| 0.26 - 10.5 GPM (DN7) | 11356 |
| 0.52 - 21 GPM (DN10)  |       |
| 1.45 - 58 GPM (DN17)  | 2063  |

Check the yellow sticker on your manual packet for your flow calibration number or the side of the flowmeter

### Turbine Flowmeters

<p>FM750 Reg          Micro-Trak Cal Number - 145 (SprayMate, Auto-X)          Pulses Per Gallon - 72.50 (JD, AGL, Trimble)          Pulses Per 10 Gallon - 725 (Raven)</p> <p>FM750 LF          Micro-Trak Cal Number - 466 (Spraymate, Auto-X)          Pulses Per Gallon - 233 (JD, AGL, Trimble)          Pulses Per 10 Gallon - 2330 (Raven)</p>
---

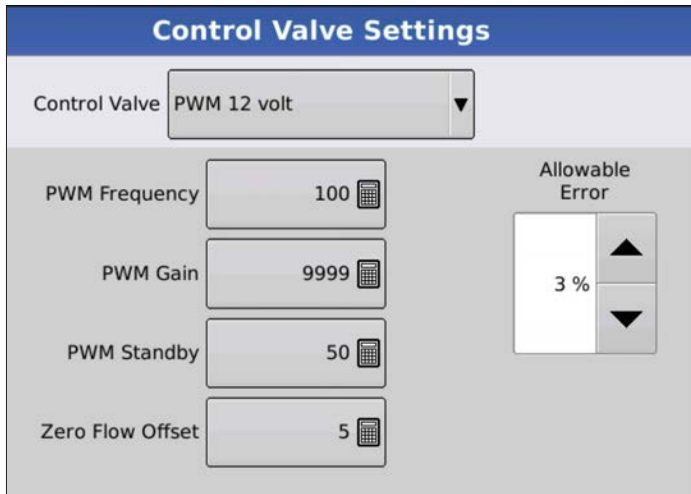

Press the **Control Valve Settings** button on the **Control Settings** screen. This will bring up the **Control Valve Settings Screen**. Set the settings as shown:

#### Control Valve:

PWM 12 volt

#### PWM Frequency:

- GX5 (hydraulic diaphragm)...100
- GX5 (hydraulic centrifugal)...122
- GX2.....100

#### PWM Gain:

- GX5 (hydraulic diaphragm).....2500
- GX5 (hydraulic centrifugal).....150
- GX2 (electric)..... 9999

#### PWM Standby\*:

All Systems.....50

#### Zero Flow Offset\*\*:

- GX5 (hydraulic diaphragm).....20
- GX5 (hydraulic centrifugal).....20
- GX2 (electric).....10

#### Allowable Error:

All Systems.....2%

**\*Note:** PWM Standby setting is not used if Flow Control Valve is set to Close, but still needs to be set.

**\*\*Note:** Zero Flow Offset can be set higher if system is slow to reach Target Rate when starting. Can be set lower if pump will not go slow enough for low rates.



# Quick Start Setup Instructions for AgLeader Integra and InSight Rate Controller

## Configuration – Pressure Calibration

- The AgXcel harness includes a connection for an electronic pressure sensor.\* The sensor is identified as “**Main Pressure**” in the AgLeader display.
- From the **Configuration Setup** screen, choose **Calibrate Main Pressure**.
- Enter values in the calibration
- **\*Note: The pressure sensor is an optional feature!**

## Configuration – Calibration

- *AgXcel highly recommends you perform these exact steps with water to verify that your AgXcel System is correctly installed and ready for field use.*
- On the **Home** screen, select your **Operator** and your **Equipment** that you will be using
- Press the **Select Event** button
- Select **Growing Season, Grower, Farm, & Field** from the drop-down box or add new selection by pressing the green “+” button. Press the right arrow button.
- On the **Product Selection** screen, select the product being used from the drop-down box or press the green “+” key to create a new product. When completed press the right arrow button.

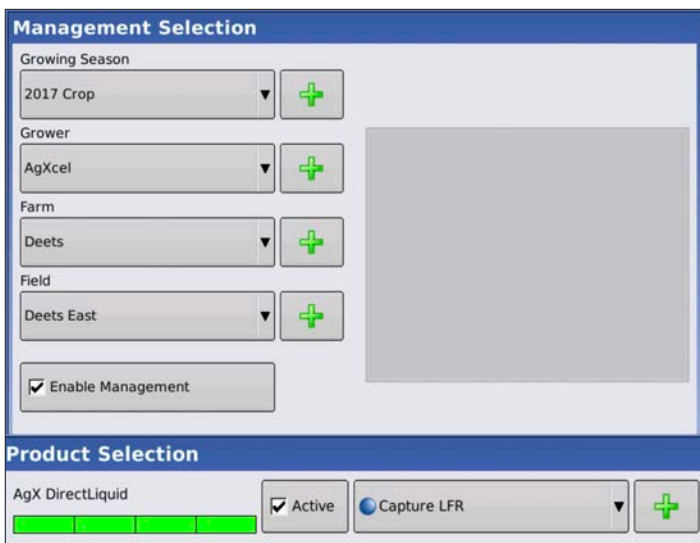
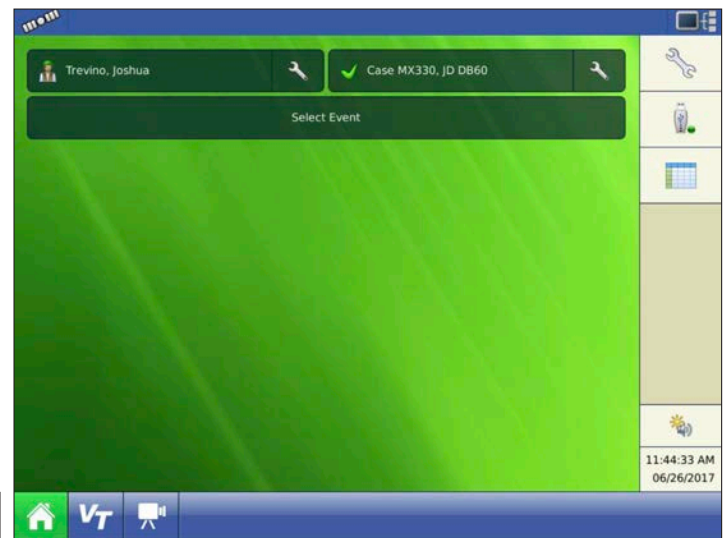
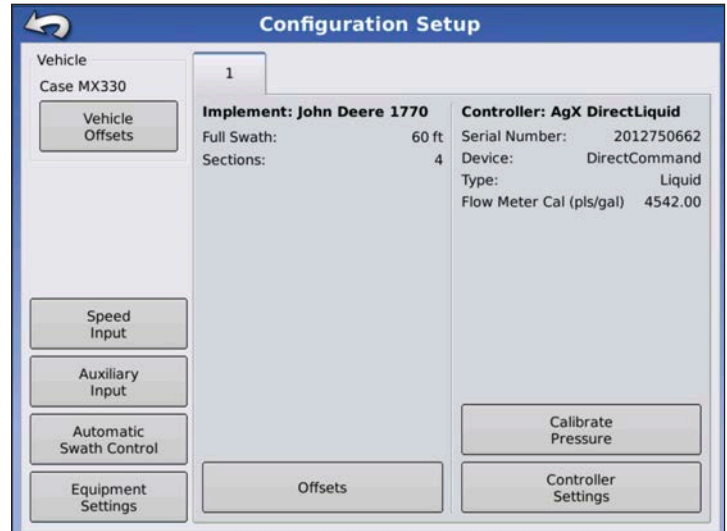



# Quick Start Setup Instructions for AgLeader Integera and InSight Rate Controller

## Configuration – Calibration cont.

- You can select a previous event that has been created or you can create a new event by pressing the **Start New Event** on the **Event Selection Screen**.
- Finally, select the **region** and the **controlling product**. When this is complete, select the green check mark button to finish setting up a new field.
- The **Home Screen** will now have an **Operator, Equipment, and Event** selected and loaded.
- Press the **Grid icon (Map)** on the bottom left of the **Home Screen**.
- **Note:** To simulate speed to test flow without moving, you must go to the **Configuration Setup** screen. Press the **Wrench icon** next to your selected equipment. Press the **Speed Input** on the left to enter your simulated speed in mph.





# Quick Start Setup Instructions for AgLeader Integra and InSight Rate Controller

## Configuration – Calibration cont.

- To **adjust rates**, touch the tab where the rate information is displayed.
- Rates 1 and 2** can be selected or a variable rate prescription can be loaded. Press the **Wrench** button on the right side of the rate screen.
- The **Rate Controller Settings** screen will appear. From this screen both **Rate 1 and Rate 2** can be entered along with the minimum flow. Press the **Minimum Flow** button.
- Once pressed the minimum flow threshold can be set. **AgXcel recommends the minimum flow be set to "0"**.
- After rates and minimum flow are set, return to the main operation screen to conduct a **catch test**.
- Enter the **manual mode** by pushing the **"M"** button under the **Rate 1 and Rate 2 buttons**. You can tell when you are in manual mode when the **"Target Rate"** says **"OFF"**.
- On the switch box, turn the **master switch ON**. Turn section switches **on and off** to check proper section valve operation. Leave all section valves **"ON"**
- Use the **up** arrow on the right side of the screen to increase flow. **Does "Flow Rate" display a flow rate? Is it stable after the system is primed? Do the increase and decrease buttons increase and decrease the flow?**
- Next, **perform a catch test** using either automatic rate 1 or 2 while utilizing the simulated speed set earlier. The simulated speed should be displayed in the upper right-hand corner of the screen.
- This is also a good time to ensure the rate adjusts when the section valves are turned on and off through the switchbox.**

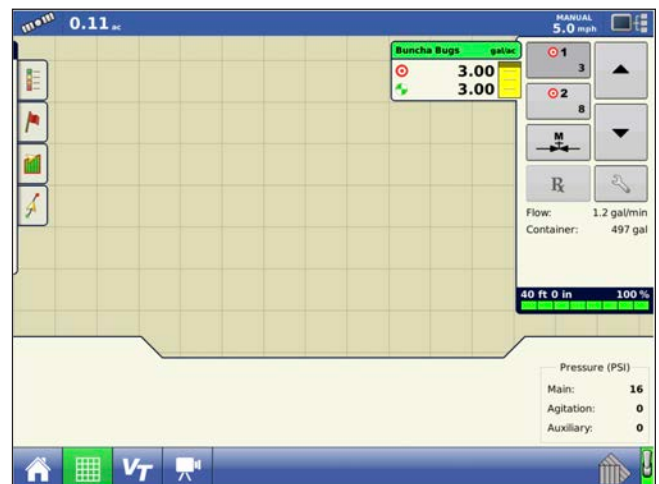
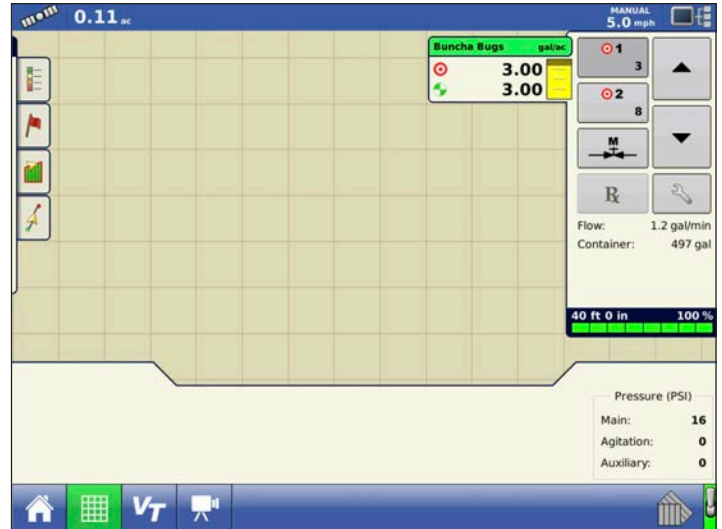



## AgXcel Liquid System Frequency Asked Questions (FAQ)

### ***I am trying to achieve 5 GPA but my system will not go lower than 9 GPA.***

- Make sure your PWM Low Limit is set to a number that is lower than your required lowest rate. This can be found in your Valve Control PWM setting on your console. If the PWM Low Limit is set too high you will not be able to achieve the lowest rate possible if set other than 10. Many times setting the Low Limit to 0 will work just fine especially when running lower rates.
- With an AgXcel System always make sure your Minimum Flow rate is set to 0.0 GPM or your system will not drop below this rate. For example if the Minimum flow rate is set to 3 GPM your system will not drop below this setting so if your required GPA requires 2.1 GPM then your system will not achieve this rate given that you have set the Minimum Flow rate to 3 GPM.
- When using an AgXcel GX5 Hydraulic system, make sure the AgXcel silver hyd valve is NOT in manual override. Check to ensure that the RED knob on top of the valve is pressed down by turning the knob clockwise while pressing the RED knob down. This will lock the PWM valve down so that the electronic solenoid can control the hyd flow.

### ***I am trying to achieve 12 GPA but my system will only go up to 8 GPA on my GX5 Hydraulic system or I am trying to achieve 8GPA and can only achieve 5 GPA on my GX2 electric system***

#### **AgXcel GX2 Electric System**

- What is your system pressure? If system pressure is too high (50PSI or above) this will prevent you from achieving your highest rate possible. High system pressure with an electric system can put the electric pump head into bypass mode and will not allow for full flow.
- **Check the following areas to lower your pressure**
  1. Select a larger orifice or Micro Tube with a larger hole, this will allow for easier flow of liquid through the system and can increase over all flow and GPA
  2. Check your system filters and make sure they are clean. This should be a practice each morning before using the system
- AgXcel GX2 Electric Systems can achieve up to about 5.9 GPM with dual electric pumps. Check your total GPM requirements and ensure that you are within range
- When using a Dual Pump System – unplug 1 pump and ensure that the other pump is working. Perform this test with both pumps and if one pump sounds weak replace it immediately
- Ensure that your PWM High Limit is set to 100. Many times an Auto Tune will set this to a lower number so make sure this is set to 100
- If your controller has this option make sure the PWM Duty Cycle is within range
- Check all your boom widths and make sure that all are set correctly

#### **AgXcel GX5 Hyd System**

- What is your system pressure? If system pressure is too high (90PSI or above) this will prevent you from achieving your highest rate possible. High system pressure with a hydraulic system set 100 PSI bypass spike valve to open and you could begin to lose volume
- **Check the following areas to lower your pressure**
  1. Select a larger orifice or Micro Tube with a larger hole, this will allow for easier flow of liquid through the system and can increase over all flow and GPA
  2. Check your system filters and make sure they are clean. This should be a practice each morning before using the system
- Check your total GPM requirements and ensure that you are within range of the GX5 hyd pumps recommended GPM
- Ensure that your PWM High Limit is set to 100. Many times an Auto Tune will set this to a lower number so make sure this is set to 100
- If your controller has this option make sure the PWM Duty Cycle is within range
- Check all your boom widths and make sure that all are set correctly



# AgXcel Liquid System Frequency Asked Questions (FAQ)

## AgXcel Liquid System Frequency Asked Questions (FAQ) cont....

### ***My rate is fluctuating and is almost locking in but is jumping around***

- Make sure that your Rate Smoothing is checked and set to 10. You can typically find this setting under your System Controller settings. Rate Smoothing allows the system to lock into the rate if the rate is within 10% of the required rate. Many times liquid temperature can affect the performance of the system.
- Make sure your pressure is enough to fully OPEN every check valve on the implement. A good rule of thumb is to ensure that pressure is higher than 15 PSI when using 4lb, 5lb and especially 10lb check valves

### ***How do I know where my pressure should be?***

- AgXcel systems are not pressure based especially when they are controlled with a Liquid Rate Control Module. HOWEVER, pressure can affect the performance of the system if the pressure is too low or too high. Many users feel that the higher the pressure then the less chance they have to plug an orifice. Although this statement holds value it can also have a major effect on system performance
- **Low pressure – RECOMMENDED 15PSI is the lowest**
  1. Can affect the performance of the pump and may cause it to surge which affect the accuracy of your flow
  2. Can affect the performance of your system check valves, not enough pressure and all your check valves may not OPEN and this may affect the accuracy of your system
- **High Pressure – RECOMMENDED – GX2 Electric = 25PSI GX5 Hyd = 70PSI**
  1. Too high of pressure can also affect the performance of your system as this can cause too much restriction in the manifold tubes and too much resistance will slow the rate down
- **RULE OF THUMB FOR PRESSURE**
  - AgXcel GX2 systems = 15PSI – 25 PSI
  - AgXcel GX5 Hyd systems
    - Low Range = 15PSI – 40 PSI
    - Medium Range = 20PSI – 50PSI
    - High Range = 40PSI – 80PSI
  - All these ranges are OK for the AgXcel GX5 system
  - For High Speed Planters check out the AgXcel GX30i VRT Solution

### ***How do I raise and lower my pressure when required***

- If your pressure is too HIGH then increase the size of your orifice and or Micro Tube to a larger hole size
- If your pressure is too LOW then change the size of your orifice or Micro Tube to a smaller hole

***TIP - Many times the system may have difficulty priming, or if a flow meter has not detected flow and you want the system to continue running so as to prime. Go to Diagnostics > Tests > Calibrate PWM Limits***

1. Time for Auto Mode Testing -
2. Once again, enter a Test Speed
3. Press the AUTO button
4. Ensure that the height switch is down or unchecked
5. Turn the Master ON
6. You can now monitor system flow vitals and ensure that all outlets of liquid are flowing
7. Once again, check sections if sections are being used
8. System testing is complete - Turn OFF the Master Switch

AgXcel System Performance Setting - To ensure the best performance of your AgXcel system especially at Start Up, setting the PWM Start Up % can be fine tuned. PWM Start Up % sends voltage to the pumps at the % that has been set. This can assist in the priming cycle to get the pumps running quicker. Once the pumps jump up to the % set, then it will begin its cycle to lock into the required target rate setting



# Quick Start Setup Instructions for AgLeader Integra and InSight Rate Controller

Wire Size: 18 AWG  
unless otherwise  
specified

## AgLeader Adapter Cable P/N 53514

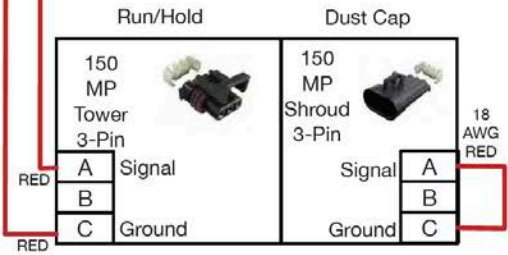
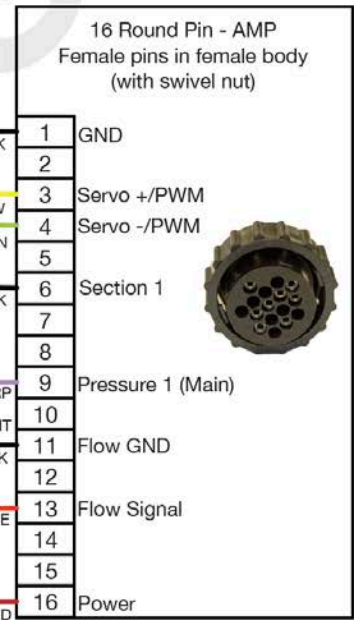
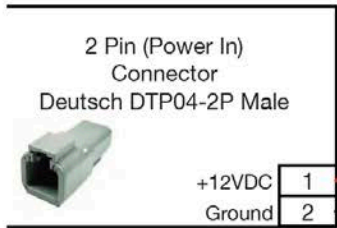
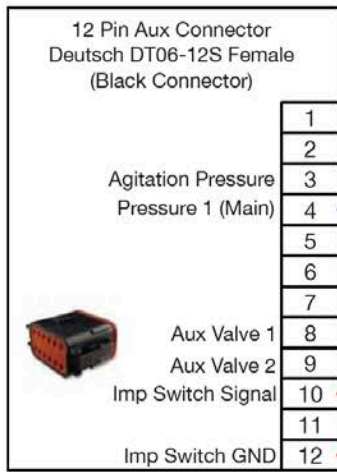
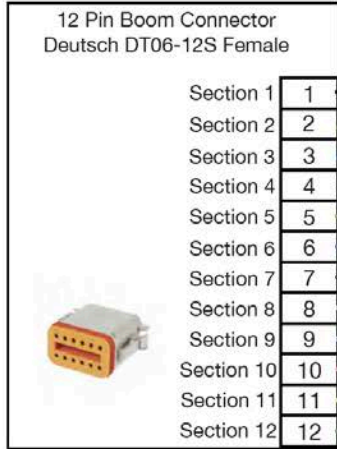



# Quick Start Setup Instructions for AgLeader Integera and InSight Rate Controller

## PWM Harness Flowmeter, PWM, Pressure P/N 53697

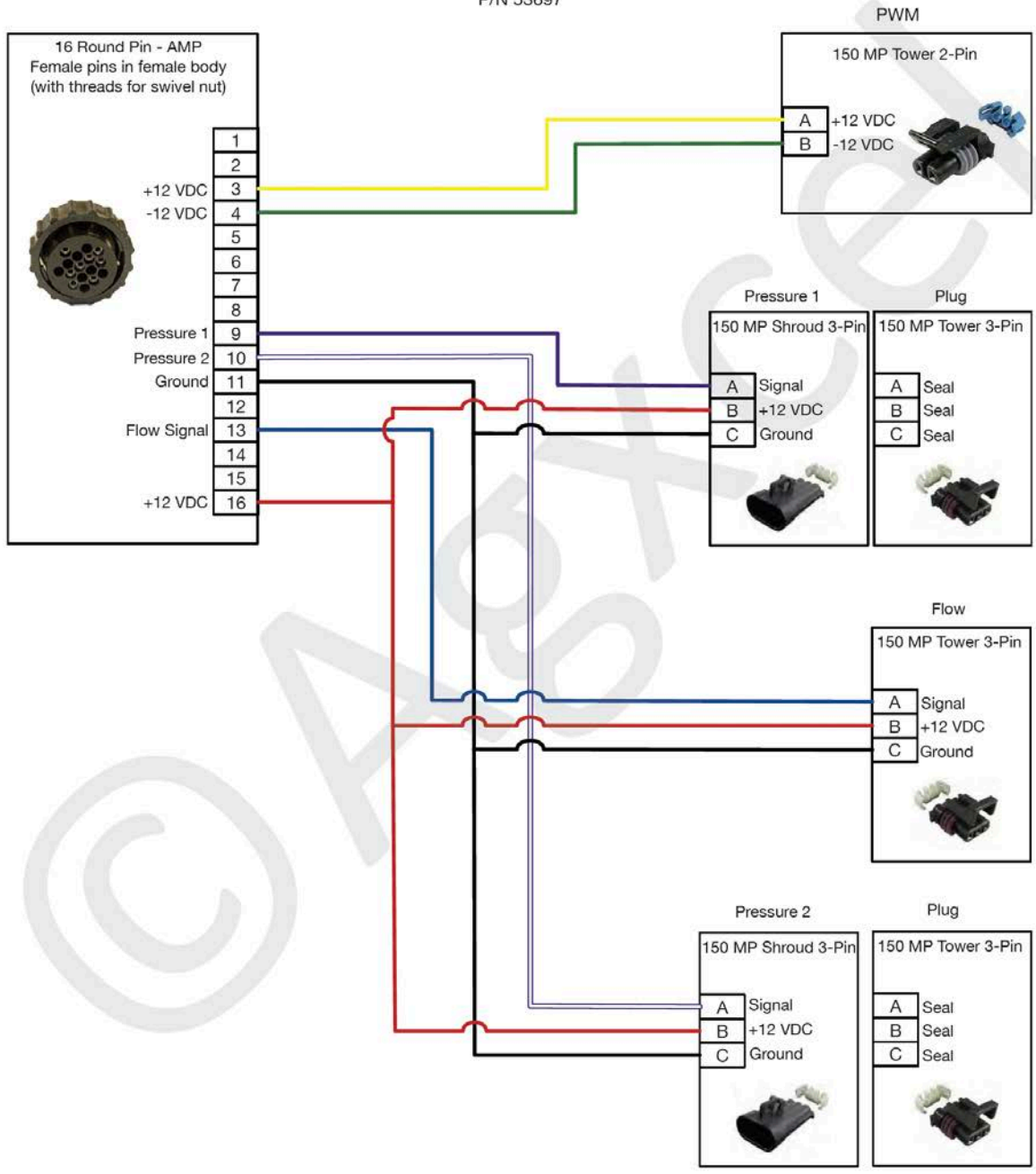

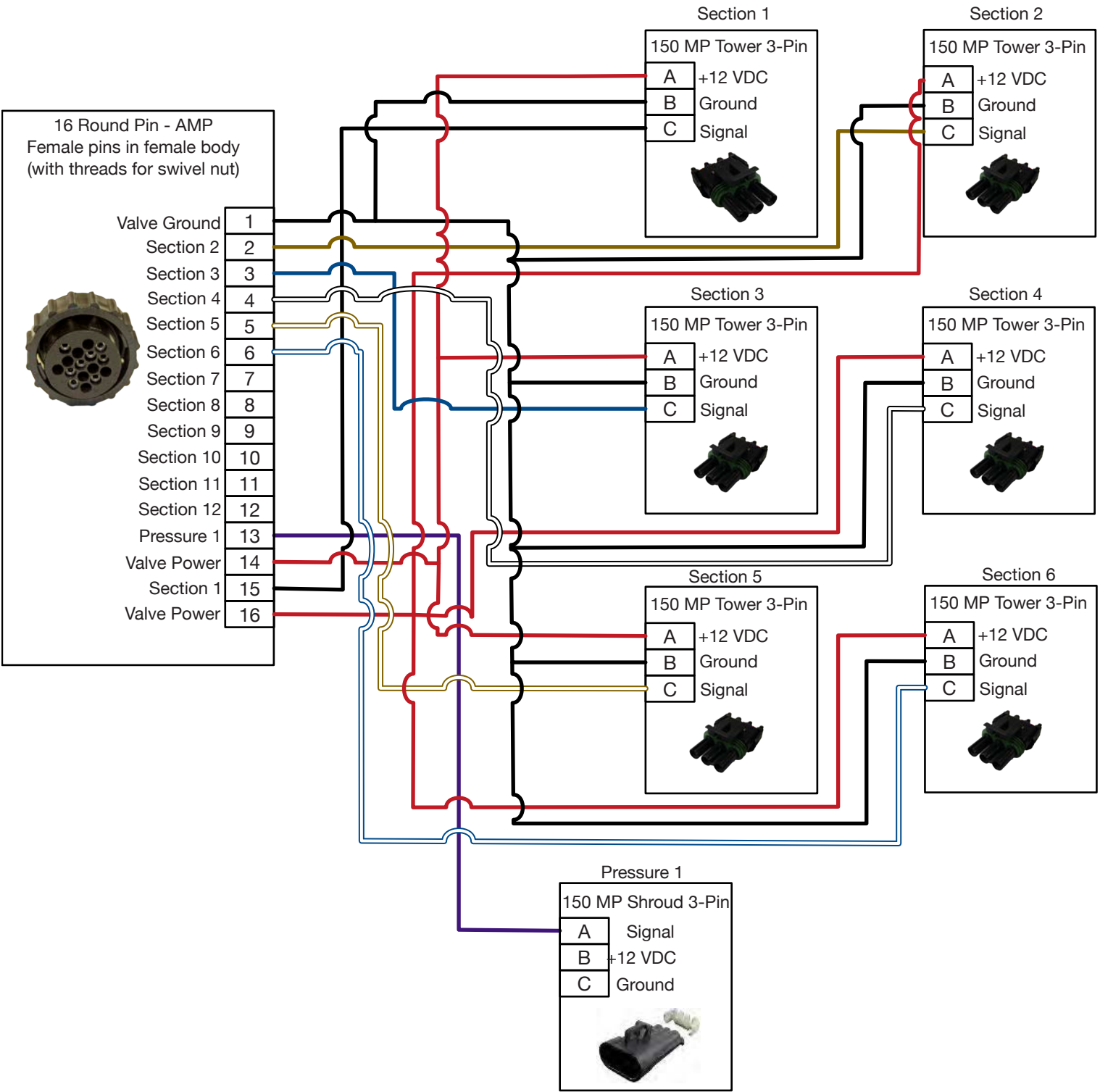

# 12 Section Boom Harness

P/N 53800

